



# Installation and Maintenance Instructions

**THESE INSTRUCTIONS MUST BE READ FULLY BEFORE COMMENCING INSTALLATION**

## HDYR100 & HDYR150 Hair Dryer

Code	Supply	Watts	Amps
HDYR100	220-240V/1Ph/50Hz	1000	4.3A
HDYR150	220-240V/1Ph/50Hz	1500	6.8A

### Parts:

1. LCD Screen
2. Button
3. Micro Switch
4. Panel
5. Shaver Socket
6. Base
7. Air Outlet Handle

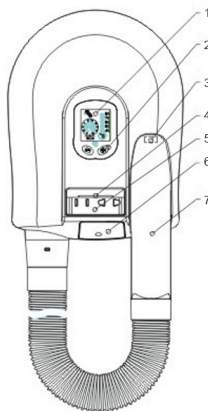

### 1.0 GENERAL

- 1.1 It is important these Installation and Maintenance Instructions are fully adhered to.
- 1.2 Full details of the unit supplied are shown on the product nameplate. If in doubt about any detail contact HYDOR or its agents for clarification.
- 1.3 All electrical installation must be carried out by suitably qualified and competent personnel in accordance with all current statutory requirements.
- 1.4 Any declarations made by HYDOR about product installation and safety, are dependant on the hair dryer being used within installations which themselves meet the requirements of the relevant Standards and Directives of your region.
- 1.5 The hair dryer must be installed indoors in a dry, sheltered position and is designed for use in an ambient temperature of up to 40 °C. The hair dryer is not suitable for corrosive or explosive atmospheres.
- 1.6 The installer should provide easy access to the hair dryer to facilitate future maintenance.
- 1.7 The installer should ensure the hair dryer is adequately supported.
- 1.8 This product is not intended for use by persons (including children) with reduced physical, sensory or mental capabilities, or lack of experience and knowledge, unless they have been given supervision or instruction concerning use of the product by a person responsible for their safety. Children should be supervised to ensure that they do not play with the product.

## 2.0 INSTALLATION

**WARNING – The hair dryer is an IPX1 electrical appliance and must not be installed in an area where there is any possibility of water ingress. The hair dryer must be isolated from the power supply during installation and maintenance. The hair dryer must be earthed in accordance with the local regulations.**

- 2.1 Upon receipt, the hair dryer should be visually inspected to check for any damage.
- 2.2 Check the details on the rating plate to ensure that the correct power supply (voltage, frequency and phase) is available.  
An incorrect power supply will lead to permanent damage to the hair dryer.
- 2.4 Take care not to put any strain on the connecting wire.
- 2.5 Mark and drill 6mm diameter by 35mm deep holes per Fig 2.
- 2.6 Attach the base using the screws and plugs provided. Refer to Fig. 2.
- 2.7 Refer to the appropriate wiring diagram. Ensure that all earth connections are made.
- 2.8 Means for electrical disconnection must be incorporated in the wiring installation in accordance with the relevant wiring and electrical regulations.
- 2.9 Fit the appliance to the wall per Fig. 2. Insert the plugs into the drilled holes and attach using the hanger and screws provided.

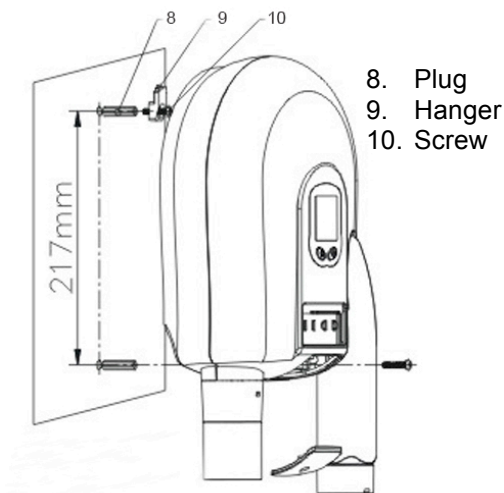

Fig 2.

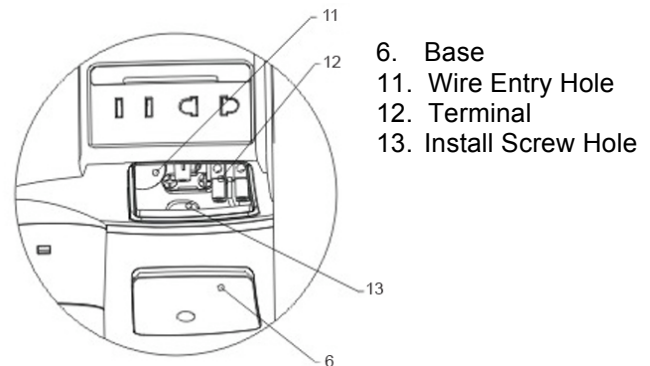

Fig 3.

## 3.0 START-UP

- 3.1 Before power is supplied to the unit, ensure that the wiring is correct as per the connection diagram.
- 3.2 Lift the dryer to activate the hair dryer. The hair dryer will stop once the hair dryer is replaced in its holding position.
- 3.3 Lifting the handle again will re-activate the hand dryer.
- 3.4 Check that the motor amperage draw does not exceed the nameplate rating.

#### **4.0 FAN MAINTENANCE**

- 4.1 Inspection of the hair dryer at least once every 12 months is recommended to ensure that the motor, fan blades, and supporting guards, are clean. Any build up of dust and deposits on the blades or guards should be removed using a non-abrasive cleaner.
- 4.2 All fastenings should be checked for tightness. In addition, all rotating items should be checked.
- 4.3 Bearings are of the 'sealed for life' type and will not need a detailed inspection.

**WARNING – Do not cover the air inlet and outlet. The hair dryer is fitted with thermal protection which switches the heating element off in the event of a fault condition. Only a suitably qualified and competent person may carry out maintenance after the electrical supply has been isolated.**

#### **GUARANTEE**

**HYDOR or its agents will, within a period of 1 year from the date of dispatch from their works, repair or, at its option, replace any goods, which are proven to have defects as a result of defective materials or workmanship. The goods MUST be returned to HYDOR, carriage paid, for examination.**

##### **Hydor Ltd.**

8 Parkers Close, Downton Business Centre  
Downton, Salisbury, Wiltshire  
SP5 3RB, UK

TEL: +44 (0) 1725 511422 FAX: +44 (0) 1725 512637 email: [info@hydor.co.uk](mailto:info@hydor.co.uk)

##### **Hydor Ventilation Aust**

42-62 Pound Road West  
Dandenong South  
Vic 3175

TEL: 1300 655 730 FAX: 1300 134 319 email: [info@hydor.com.au](mailto:info@hydor.com.au)

##### **Hydor Ventilation SA**

11 Ingrid Road  
Montague Gardens  
Capetown  
7441

TEL: +27 (0) 21 552 1077 FAX: +27 (0) 21 552 2797 email: [info@hydor.co.za](mailto:info@hydor.co.za)