



MH42 Horizontal Baby Changing Unit

The MH42 horizontal, fold-down baby changing unit combines innovative design with the latest safety features. This compact, stylish unit will enhance any washroom.

Colour Options



White Fleck



Oatmeal



Fully Compliant with **BS EN 12221: 2008** ✓



- » New, contoured contemporary design
- » Unique hinge construction eliminates finger traps
- » Choice of colour to enhance any project
- » Extra deep sides increase safety and eliminate the need for straps
- » Withstands static loads in excess of 100Kgs
- » Hygienic, easy-clean surface

Key Features



The unique hinge construction eliminates finger traps even during opening and closing. The hinge rotates within the enclosed moulding eliminating exposure to moving parts.



Superior integral strength, with stainless steel reinforced hinge, withstands static loads in excess of 100Kgs. Strong enough even for a baby elephant!



Extra deep barriers provide natural protection. This intrinsic safety feature eliminates the uncertainty involved in the use of straps. Easy to install with Magrini fixing kit.

Specification Clause - Manufacturer: Magrini Ltd., Tel: 01543 375311 Fax: 01543 361172. Horizontal baby changing unit, Ref: MH42. Size: 760mm (width), 585mm (height), 145mm (closed depth), 540mm (open depth). Material: MDPE with enclosed stainless steel reinforced hinge and gas strut closing mechanism. Colour option: Oatmeal or White Fleck. Installation kit as supplied by manufacturer. Fully compliant with BS EN 12221:2008 and Decree 91-1292 for use in the public domain.

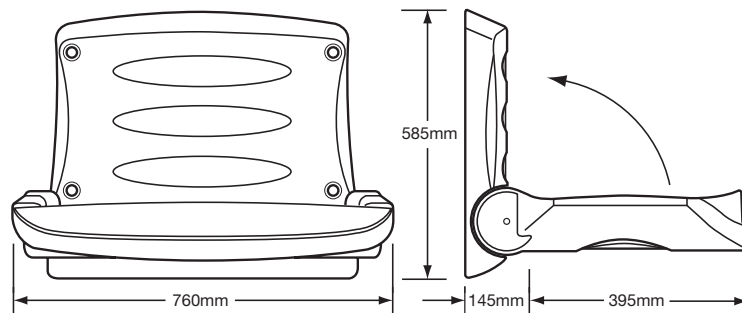

Suggested mounting height from the floor to the base of the unit is 730mm

SAFETY STANDARDS

The Magrini MH42 is fully compliant with and independently tested to BS EN 12221:2008 and Decree 91-1292 for use in the public domain.



Designed and Manufactured in the UK

